



This manual remains the sole property of Dexion Commercial (New Zealand) Limited (Precision). It must not be copied without prior consent and must be returned on request. The information contained within this manual is to be regarded as confidential and must not be disclosed to any third party.

Whilst the utmost care is taken to ensure the accuracy of data and design details within, Precision cannot, under any circumstances, be held liable for any injuries, expenses or loss which may, in any degree, be attributed to the use or adoption of such data and design details.

Any modification, repair, or alteration of the products described herein by a third party, without written approval, voids Precision's warranty obligations.

© Copyright:
Dexion Commercial (New Zealand) Limited
25 Peterkin Street
Wingate
Lower Hutt 5045
New Zealand

Phone: +64 4 920 5400
Fax: +64 4 920 5402

Date of issue: May 2011

Issue/ Amendment	Date Issued	Description	Notes
1	May 2009	Initial manual release	
2	May 2011	Updated for new post and centre brace design	

Table of Contents

- **SECTION 1 PRODUCT INTRODUCTION**

1.1 Introduction.....	Page 6
1.2 Parameters of the System.....	Page 7

- **SECTION 2 COMPONENT DESCRIPTIONS**

2.1 Assembly drawings and component identification	
▪ Wall mounted.....	Page 8
▪ Freestanding single sided.....	Page 8
▪ Freestanding double sided.....	Page 8
▪ Mobile unit double sided.....	Page 8
▪ Accessories.....	Page 9
2.2 Component descriptions	
▪ 2.2.1 Posts single faced.....	Page 10
▪ 2.2.2 Posts double faced.....	Page 10
▪ 2.2.3 Centre braces.....	Page 11
▪ 2.2.4 Wall fixing brackets.....	Page 11
▪ 2.2.5 Wall channel.....	Page 11
▪ 2.2.6 Cross brace for castor bay.....	Page 12
▪ 2.2.7 Castor plain.....	Page 12
▪ 2.2.8 Castor braked.....	Page 12
▪ 2.2.9 Upstand shelves.....	Page 13
▪ 2.2.10 Overslung endplates.....	Page 13
▪ 2.2.11 Quadrant plates.....	Page 14
▪ 2.2.12 Canopy shelves.....	Page 14
▪ 2.2.13 Underslung endplates.....	Page 14
▪ 2.2.14 Uptilt shelves.....	Page 15
▪ 2.2.15 Uptilt endplates.....	Page 15
▪ 2.2.16 Slotted shelf.....	Page 15
▪ 2.2.17 Slotted shelf back.....	Page 16
▪ 2.2.18 Slotted shelf endplates.....	Page 16
▪ 2.2.19 Slotted shelf divider.....	Page 16
▪ 2.2.20 Stayput book support.....	Page 16
▪ 2.2.21 Bookend.....	Page 17
▪ 2.2.22 Pull-out reference shelf.....	Page 17
▪ 2.2.23 Hinged shelf.....	Page 18
▪ 2.2.24 Magazine shelf.....	Page 18
▪ 2.2.25 Magazine waterfall shelf.....	Page 18
▪ 2.2.26 Magazine display shelf.....	Page 18
▪ 2.2.27 Selecta shelf.....	Page 19
▪ 2.2.28 CD/ DVD shelf.....	Page 19
▪ 2.2.29 Video shelf.....	Page 19
▪ 2.2.30 CD/ DVD display shelf.....	Page 20
▪ 2.2.31 CD/ DVD display racks.....	Page 20
▪ 2.2.32 CD/ DVD display frame.....	Page 20

- 2.2.33 Browser bin Page 21
- 2.2.34 Hanging bag rail Page 21
- 2.2.35 Zig-zag shelf display Page 21
- 2.2.36 Bookshelf indicator Page 22
- 2.2.37 Floor fixing brackets Page 22
- 2.2.38 Overhead braces Page 22
- 2.2.39 Overhead splices Page 23
- 2.2.40 Seismic Cross Braces..... Page 23
- 2.2.41 End panels - plain Page 24
- 2.2.42 End panels - display Page 24
- 2.2.43 End panel display shelf Page 25
- 2.2.44 End panel fixing brackets..... Page 25
- 2.2.45 Range Label Holder..... Page 25

• **SECTION 3 DESIGNERS REFERENCE**

- 3.1 Definitions..... Page 26
- 3.2 General Layout
 - 3.2.1 Wall mounted shelving
 - 3.2.1.1 Wall channel dimensions..... Page 28
 - 3.2.1.2 Bay dimensions Page 28
 - 3.2.1.3 Overall dimensions Page 28
 - 3.2.2 Freestanding shelving
 - 3.2.2.1 Post dimensions Page 29
 - 3.2.2.2 Bay dimensions Page 29
 - 3.2.2.3 Overall dimensions Page 29
 - 3.2.3 Secure fixing
 - 3.2.3.1 New Zealand standards..... Page 30
 - 3.2.3.2 Wall mounted shelving..... Page 30
 - 3.2.3.3 Single sided freestanding shelving Page 30
 - 3.2.3.4 Doubled sided freestanding shelving..... Page 30
 - 3.2.4 Floor Quality Page 31
 - 3.2.5 Storage capacity Page 31
- 3.3 Load Information
 - 3.3.1 General Page 32
 - 3.3.2 Shelf loads Page 32
 - 3.3.3 Bay loads Page 32
- 3.4 Standard Bay Construction Times Page 32

Section 1 – PRODUCT INTRODUCTION

1.1 INTRODUCTION

Precision's Library Shelving is a cantilever, post based system designed to discretely display and store all forms of library content. Available in a wide range of heights, widths and depths allows full and efficient use of space and material storage. Being modular enables easy reconfiguration or addition. Units can be wall mounted, freestanding or mobile on castors.

An extensive range of accessories are available to solve any diverse library display and storage requirement.

- **Posts**
Single or double faced welded RHS, available in a range of standard heights
- **Wall Channel**
Folded steel U section
- **Shelves**
Horizontal load-bearing shelves which clip into fully adjustable end plates
- **Accessories**
A full range of accessories designed to extend the versatility of the system
- **Adjustability**
The slotted posts and wall channel allow easy adjustment at 38.1mm increments
- **Finishes and Colour**
All steel components are finished in a standard range of colours. The colour application process commences with a five stage pre-treatment system to remove any foreign material and apply corrosion resistant solutions to the steel components. Each colour is applied as a powder, electro statically charged to provide adhesion prior to baking and final curing. After application the powder-coat is oven baked to 200 degrees celsius, providing an extremely hardwearing and aesthetic finish

1.2 PARAMETERS

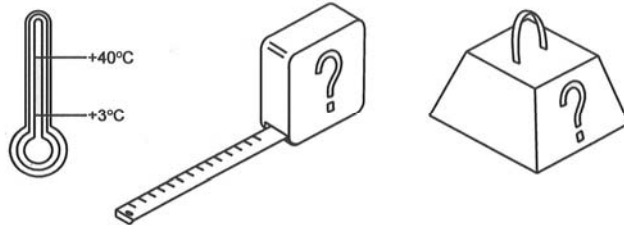

The Precision Library shelving product has been designed to operate within the following standard parameters.

Floor

The floor should be of solid construction designed to accept loads imposed by the system. Installations on carpet or similar floor coverings should be mindful of the floor substrate below and that the floor covering will not compress in an uneven manner.

Loads

Individual loads should be stable and self supporting, with a maximum unit weight within the safe working recommendations.

Operating Conditions

Components and load data are based on dry internal applications.

Temperature Range

+3 degrees C to +40 degrees C

Note:

For applications that require operating parameters outside those indicated above, please contact Precision for technical guidance on your particular application.

Section 2 – COMPONENT DESCRIPTIONS

2.1 ASSEMBLY DRAWINGS AND COMPONENT IDENTIFICATION

Wall Mounted

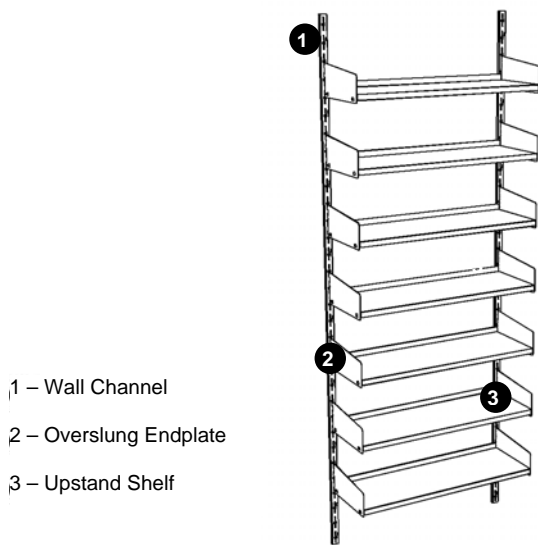

- 1 – Wall Channel
- 2 – Overslung Endplate
- 3 – Upstand Shelf

Freestanding Single Sided

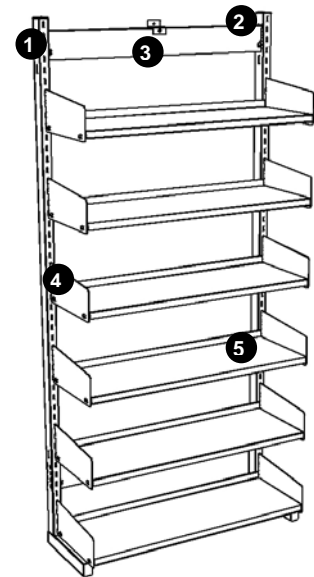

- 1 – Single Faced Post
- 2 – Centre Brace
- 3 – Wall Fixing Bracket
- 4 – Overslung Endplate
- 5 – Upstand Shelf

Freestanding Double Sided

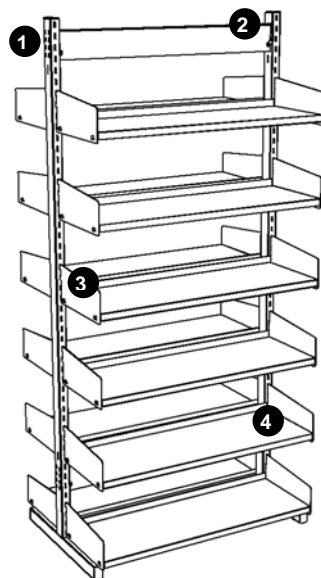

- 1 – Double Faced Post
- 2 – Centre Brace
- 3 – Overslung Endplate
- 4 – Upstand Shelf

Double Sided Mobile

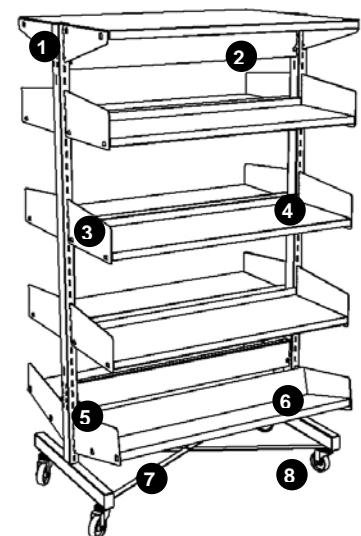

- 1 – Double Faced Post
- 2 – Centre Brace
- 3 – Overslung Endplate
- 4 – Upstand Shelf
- 5 – Uptilt Endplate
- 6 – Uptilt Shelf
- 7 – Cross Brace
- 8 – Castor

Accessories

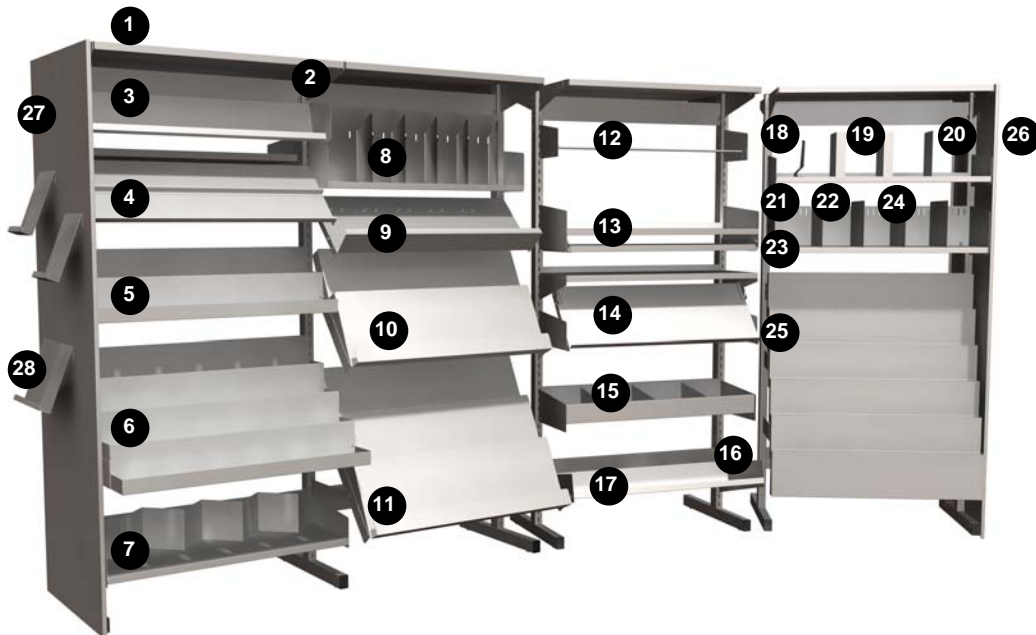

- | | |
|------------------------------------|--------------------------------------|
| 1 – Canopy Shelf | 15 – Browser Bin |
| 2 – Underslung Endplate | 16 – Uptilt End Plates |
| 3 – CD / DVD Shelf | 17 – Uptilt Shelf |
| 4 – CD / DVD Display Shelf | 18 – Stayput Book Support |
| 5 – CD / DVD Display Rack 2 Tier | 19 – Bookshelf Indicator |
| 6 – CD / DVD Display Rack 4 Tier | 20 – Bookend |
| 7 – Zigzag Shelf Display | 21 – Slotted Shelf Endplate |
| 8 – Selecta Shelf | 22 – Slotted Shelf Back |
| 9 – Magazine Shelf | 23 – Slotted Shelf |
| 10 – Magazine Display Shelf 2 Tier | 24 – Slotted Shelf Divider |
| 11 – Magazine Display Shelf 3 Tier | 25 – Magazine Waterfall Shelf 6 Tier |
| 12 – Hanging Bag Rail | 26 – End Panel Plain |
| 13 – Pull Out Reference Shelf | 27 – End Panel Display |
| 14 – Hinged Shelf | 28 – End Panel Display Shelf |

2.2 COMPONENT DESCRIPTIONS

2.2.1 POSTS SINGLE FACED

Single faced posts are a rectangular tube section, with welded base, slotted to accept shelf end plates or accessories. Posts are available in a variety of heights.

Material

51mm x 35mm x 2.0mm thick steel;
Molded plastic end caps.

Finish

Powder coated

Sizes

Standard heights are 1205mm, 1510mm, 1815mm, 1965mm, 2120mm and 2270mm;
Depth (overall base) is 312mm.

Adjustability

One 35mm face is slotted at 38.1mm or 1 1/2", intervals (pitch)

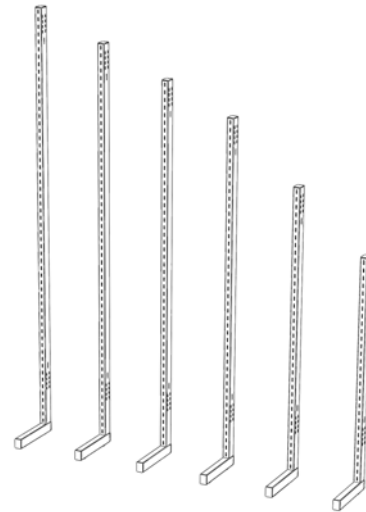

Code	Description	Weight (kg)
92702	Library post single faced 1205mm	3.91
92704	Library post single faced 1510mm	4.73
92706	Library post single faced 1815mm	5.67
92707	Library post single faced 1965mm	6.07
92708	Library post single faced 2120mm	6.38
92709	Library post single faced 2270mm	6.87

2.2.2 POSTS DOUBLE FACED

Double faced posts are a rectangular tube section, with welded base, slotted to accept shelf end plates or accessories. Posts are available in a variety of heights.

Material

51mm x 35mm x 2.0mm thick steel;
Molded plastic end caps.

Finish

Powder coated

Sizes

Standard heights are 1205mm, 1510mm, 1815mm, 1965mm, 2120mm and 2270mm;
Depth (overall base) is 565mm.

Adjustability

Both 35mm faces are slotted at 38.1mm, or 1 1/2", intervals (pitch)

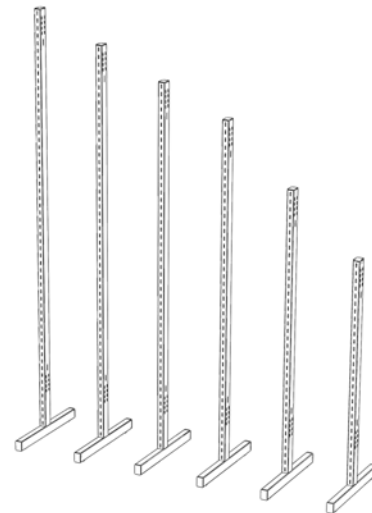

Code	Description	Weight (kg)
92712	Library post double faced 1205mm	4.38
92714	Library post double faced 1510mm	5.42
92716	Library post double faced 1815mm	6.28
92717	Library post double faced 1965mm	6.65
92718	Library post double faced 2120mm	7.06
92719	Library post double faced 2270mm	7.50

2.2.3 CENTRE BRACE

Centre braces are fixed horizontally between posts using corresponding lugs and slots to create correct modular spacing and provide secure structural support. 2 x centre braces are required for every bay. Combination centre brace / tie strut units allow for the connection of centre braces to existing tie strut constructed shelving

Material

1.2mm cold rolled mild steel
1.6mm cold rolled mild steel brackets

Finish

Powder coated

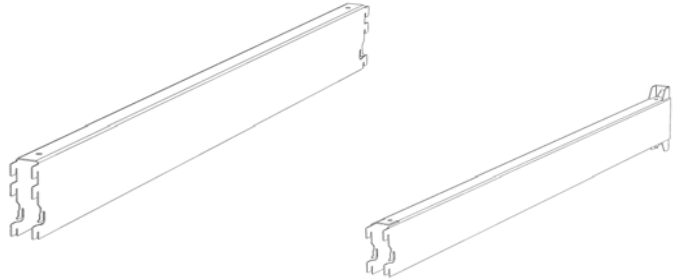

Code	Description	Weight (kg)
92720	Centre brace 600mm (nominal)	1.14
92721	Centre brace 900mm (nominal)	1.63
92722	Centre brace / Tie Strut 600mm (nominal)	1.14
92723	Centre brace / Tie Strut 600mm (nominal)	1.63

2.2.4 WALL FIXING BRACKETS

Wall fixing brackets are required to securely attach single faced freestanding bays to the wall behind. 1 x bracket required for every bay

Material

2.0mm cold rolled mild steel

Finish

Powder coated



Code	Description	Weight (kg)
92545	Wall fixing bracket	0.1

2.2.5 WALL CHANNEL

Wall channels are a folded 'U' section slotted to accept shelf end plates or accessories. These are secured to walls as an alternative to single faced post units

Material

2.0mm cold rolled mild steel

Finish

Powdercoated

Sizes

Standard height is 2438mm
Depth is 13mm

Adjustability

Slotted at 38.1mm, or 1 1/2", intervals (pitch)



Code	Description	Weight (kg)
92443	Wall channel 2438mm	2.04

2.2.6 CROSS BRACE FOR CASTOR BAY

A pair of braces is required at the base of every mobile shelving unit which. These are attached to diagonally opposite post feet and are bolted in the centre. Recommended maximum post height for mobile units is 1510mm.

Material
25mm x 3.0mm flat steel

Finish
Powder coated

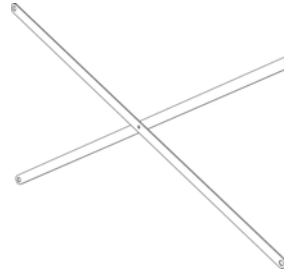

Code	Description	Weight (kg)
92549	Cross brace for 900mm module	1.21

2.2.7 CASTOR - PLAIN

75mm diameter plain castor to convert static shelving bays to mobile. Adjustable levelling feet are removed from bottom of post and the castors are attached utilising the vacated nutsert using an M10 x 40mm bolt.

Finish
Black plastic wheel
Zinc plated body

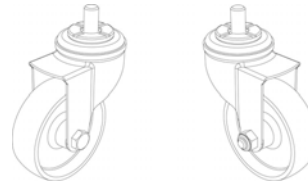

Code	Description	Weight (kg)
92563	Castor plain 75mm with fixing	0.32

2.2.8 CASTOR - BRAKED

75mm diameter plain castor to convert static shelving bays to mobile. Adjustable levelling feet are removed from bottom of post and the castors are attached utilising the vacated nutsert using an M10 x 40mm bolt. Castor has an integrated brake to prevent movement of unit from desired location.

Finish
Black plastic wheel
Zinc plated body

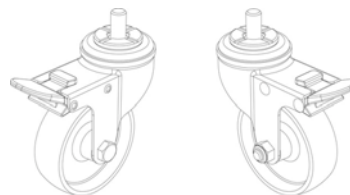

Code	Description	Weight (kg)
92564	Castor braked 75mm with fixing	0.38

2.2.9 UPSTAND SHELVES

Standard flat library shelf with 27.5mm rear upstand

Material

0.75mm high tensile cold rolled mild steel

Finish

Powder coated

Sizes

Standard widths are 600mm and 900mm

Standard depths are 203mm, 254mm, 305mm and 381mm

Adjustability

To 38.1mm, or 1 ½", intervals (pitch), with end plates or brackets

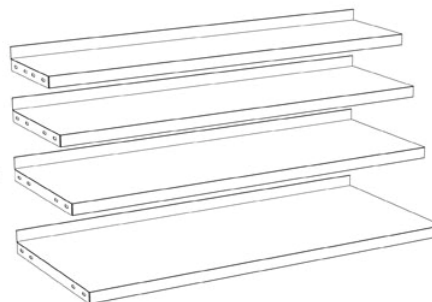

Code	Description	Weight (kg)
92400	Upstand shelf 600mm x 203mm	1.01
92401	Upstand shelf 600mm x 254mm	1.29
92402	Upstand shelf 600mm x 305mm	1.49
92403	Upstand shelf 600mm x 381mm	1.78
92404	Upstand shelf 900mm x 203mm	1.62
92405	Upstand shelf 900mm x 254mm	1.91
92406	Upstand shelf 900mm x 305mm	2.19
92407	Upstand shelf 900mm x 381mm	2.62

2.2.10 OVERSLUNG ENDPLATES

Overslung endplates are used to hold upstand shelves in a horizontal position. The endplates sit above the finished surface of the shelf and act as a book end stops. One pair of end plates required per shelf

Material

1.60mm cold rolled mild steel

Finish

Powder coated

Adjustability

To 38.1mm, or 1 ½", intervals (pitch).

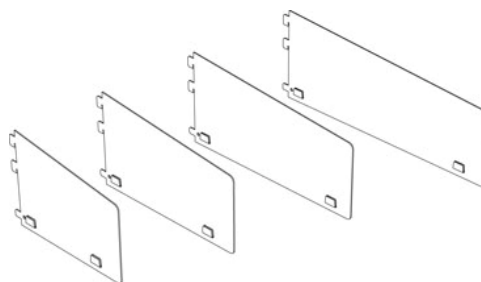

Code	Description	Weight (kg)
92543	Overslung endplate 203mm (pair)	0.69
92544	Overslung endplate 254mm (pair)	0.85
92546	Overslung endplate 305mm (pair)	1.02
92547	Overslung endplate 381mm (pair)	1.28

2.2.11 QUADRANT PLATES

Used to convert flat upstand shelves into angled display units. The brackets allow for multi-positional shelf settings of 45 degrees, 65 degrees and 85 degrees below the standard horizontal setting. One pair of end plates required per shelf

Material

1.60mm cold rolled mild steel

Finish

Powder coated

Adjustability

To 38.1mm, or 1 1/2", intervals (pitch)

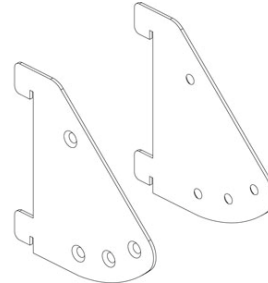

Code	Description	Weight (kg)
92509	Quadrant plate (pair)	0.13

2.2.12 CANOPY SHELVES

A flat plain shelf positioned at the top of a shelving unit to protect items on below shelves from dust and other matter. Shelves are notched to fit snugly around post and wall channel profiles. Used with underslung endplates of corresponding size (ordered separately)

Material

Single faced shelves 0.75mm high tensile cold rolled mild steel
Double faced shelves 0.95mm high tensile cold rolled mild steel

Finish

Powder coated

Sizes

Standard widths are 600mm and 900mm
Standard depths are 286mm and 337mm

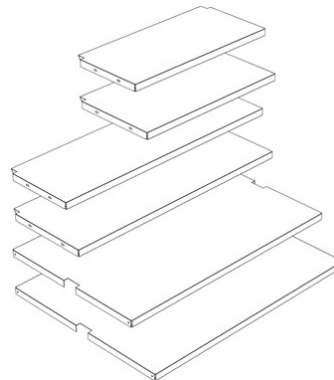

Code	Description	Weight (kg)
92408	Canopy shelf single faced 600mm x 286mm	1.33
92409	Canopy shelf single faced 600mm x 337mm	1.52
92411	Canopy shelf single faced 900mm x 286mm	1.96
92412	Canopy shelf single faced 900mm x 337mm	2.24
92565	Canopy shelf double faced 900mm x 572mm (286/286)	4.70
92566	Canopy shelf double faced 900mm x 674mm (337/337)	5.46

2.2.13 UNDERSLUNG ENDPLATES

Use for canopy shelves. One pair of end plates required per single faced shelf, two pair required per double faced shelf.

Material

1.60mm cold rolled mild steel

Finish

Powder coated

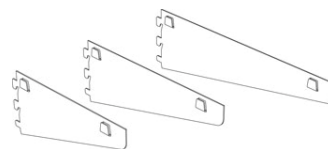

Code	Description	Weight (kg)
92553	Underslung endplate 254mm (pair)	0.49
92554	Underslung endplate 305mm (pair)	0.60
92555	Underslung endplate 381mm (pair)	0.73

2.2.14 UPTILT SHELVES

Shelf with 100mm rear upstand. Generally located at the bottom of a shelving unit, on uptilt endplates (ordered separately), to provide easier viewing and access to lower level displays.

Material

0.75mm high tensile cold rolled mild steel

Finish

Powder coated

Sizes

Standard width is 900mm

Standard depths are 203mm, 254mm and 305mm

Adjustability

To 38.1mm, or 1 1/2", intervals (pitch), with end plates

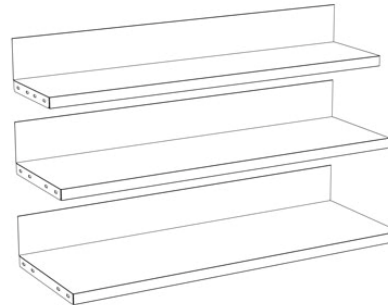

Code	Description	Weight (kg)
92567	Uptilt shelf 900mm x 203mm x 100mm	2.01
92568	Uptilt shelf 900mm x 254mm x 100mm	2.30
92569	Uptilt shelf 900mm x 305mm x 100mm	2.60

2.2.15 UPTILT ENDPLATES

Angled endplates set to a 15 degree pitch, used with uptilt shelves. One pair of end plates required per shelf

Material

1.60mm cold rolled mild steel

Finish

Powder coated

Adjustability

To 38.1mm, or 1 1/2", intervals (pitch).

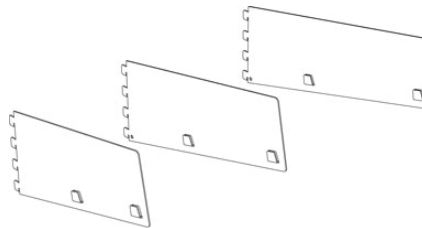

Code	Description	Weight (kg)
92556	Uptilt endplate 15 degree 203mm (pair)	0.97
92557	Uptilt endplate 15 degree 254mm (pair)	1.13
92558	Uptilt endplate 15 degree 305mm (pair)	1.29

2.2.16 SLOTTED SHELF

A slotted shelf which is able to accept steel shelf dividers (when used with slotted shelf back). Slots punched to 25mm adjustments.

Material

0.75mm high tensile cold rolled mild steel

Finish

Powder coated

Adjustability

To 38.1mm, or 1 1/2", intervals (pitch).

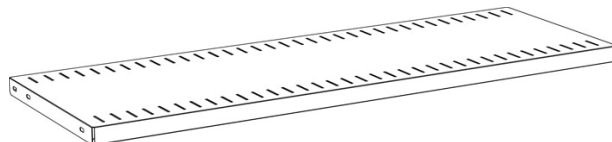

Code	Description	Weight (kg)
92416	Slotted shelf 900mm x 305mm	2.07

2.2.17 SLOTTED SHELF BACK

A slotted back panel which is used in conjunction with a slotted shelf.
Slots punched to 25mm adjustments.

Material

0.75mm high tensile cold rolled mild steel

Finish

Powder coated

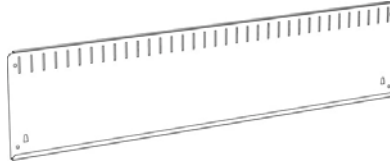

Code	Description	Weight (kg)
92417	Slotted shelf back 900mm x 205mm	1.27

2.2.18 SLOTTED SHELF ENDPLATES

Endplates to match the overall height of the slotted shelf unit. One pair of end plates required per shelf

Material

0.75mm high tensile cold rolled mild steel

Finish

Powder coated

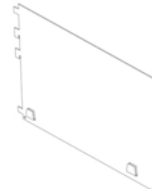

Code	Description	Weight (kg)
92534	Slotted shelf end plates 305mm (pair)	1.600

2.2.19 SLOTTED SHELF DIVIDER

Adjustable steel divider. Order quantity as required

Material

0.75mm high tensile cold rolled mild steel

Finish

Powder coated

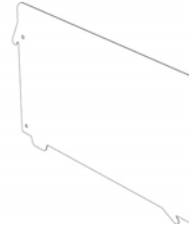

Code	Description	Weight (kg)
92418	Slotted shelf divider	0.39

2.2.20 STAYPUT BOOK SUPPORT

Profiled book support with 2 x anti-slip rubber feet

Material

1.20mm cold rolled mild steel

Sizes

127mm wide x 111mm deep x 165mm high

Finish

Powder coated

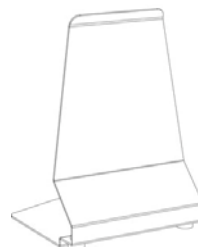

Code	Description	Weight (kg)
92469	Stayput book support (each)	0.30

2.2.21 BOOKEND

L shaped bookend

Material

0.95mm high tensile cold rolled mild steel

Sizes

175mm wide x 150mm deep x 200mm high

Finish

Powder coated

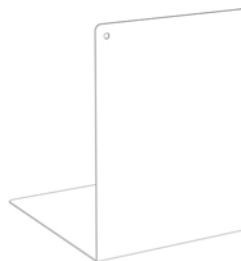

Code	Description	Weight (kg)
92512	Bookend 200mm x 175mm x 150mm	0.450

2.2.22 PULL OUT REFERENCE SHELF

A pull out work surface that can be incorporated into a shelving layout. Each kit includes a pull out shelf, standard upstand shelf and endplates

Material

0.75mm high tensile cold rolled mild steel

Finish

Powder coated

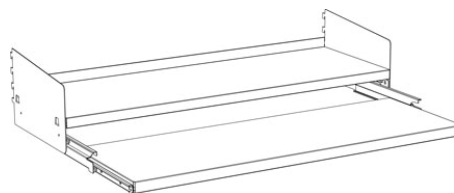

Code	Description	Weight (kg)
92516	Pullout reference shelf 900mm x 305mm	7.000

2.2.23 HINGED SHELF

This kit provides for the display of current magazines and periodicals on a 'lift up' sloping shelf, whilst storing back issues on a flat shelf behind. Each kit includes a hinged sloping shelf, a flat storage shelf and a special pair of endplates. Note that allowance is required for a shelf and endplates to the base of each periodical run.

Material

0.75mm high tensile cold rolled mild steel shelves
1.60mm cold rolled mild steel endplates

Finish

Powder coated

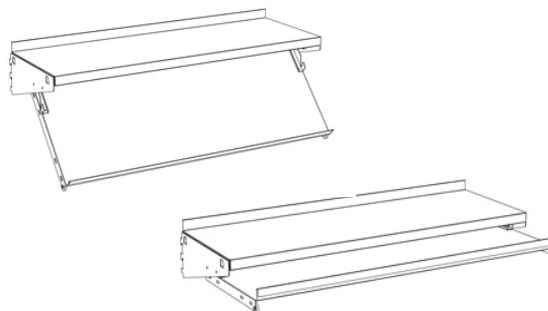

Code	Description	Weight (kg)
92414	Hinged shelf 900mm x 305mm	5.06

2.2.24 MAGAZINE SHELF

A fixed angle shelf with extra high upstand for display of magazines. Used with quadrant plates 92509 (ordered separately).

Material

0.75mm high tensile cold rolled mild steel

Finish

Powder coated

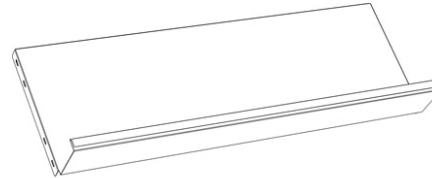

Code	Description	Weight (kg)
92551	Magazine shelf 900mm x 305mm x 100mm (upstand)	2.72

2.2.25 MAGAZINE WATERFALL SHELF

Multiple vertical shelves with acrylic fronts for mass display of magazines. Available as 3 tier or 6 tier options.

Material

0.95mm high tensile cold rolled mild steel shelves

1.60mm cold rolled mild steel brackets

5.0mm acrylic shelf fronts

Finish

Powder coated shelves and brackets

Clear acrylic shelf fronts

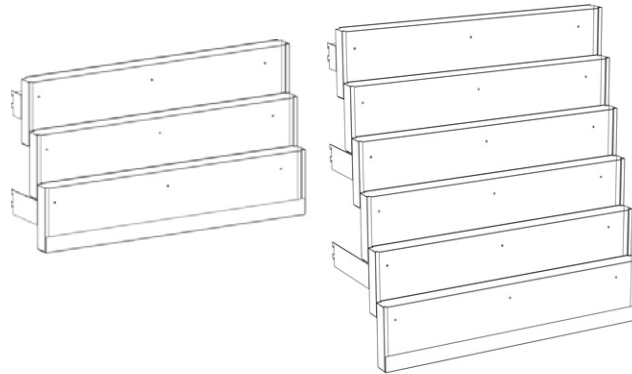

Code	Description	Weight (kg)
92570	Magazine waterfall unit 900mm wide – 3 tier	11.98
92571	Magazine waterfall unit 900mm wide – 6 tier	23.28

2.2.26 MAGAZINE DISPLAY SHELF

A fixed multi-tiered angled shelf unit for the display of magazines.

Available as 2 tier or 3 tier options.

Material

0.95mm high tensile cold rolled mild steel shelves

1.60mm cold rolled mild steel brackets

Finish

Powder coated

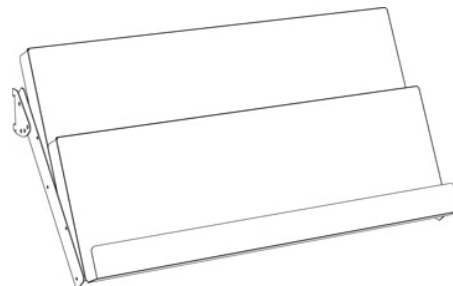

Code	Description	Weight (kg)
92572	Magazine display shelf 900mm wide – 2 tier	7.06
92573	Magazine display shelf 900mm wide – 3 tier	10.89

2.2.27 SELECTA SHELF

A divisible (50mm centres) upstand shelf that allows the vertical display of magazines and periodicals. Clear acrylic dividers are positioned at a 45 degree angle, providing effective and efficient display.

Material

- 0.75mm high tensile cold rolled mild steel shelves
- 1.20mm cold rolled mild steel endplates
- 3.00mm acrylic dividers

Finish

- Powder coated shelf unit
- Clear acrylic dividers

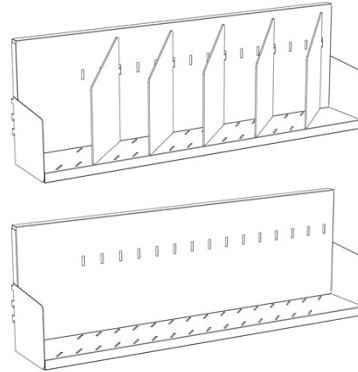

Code	Description	Weight (kg)
92515	Selecta shelf 900mm with 5 dividers	4.34
92538	Selecta shelf 900mm NO dividers	3.46

2.2.28 CD/ DVD SHELF

An angled shelf unit for the display (spine out) of CD's or DVD's. The back slope helps to keep the product on the shelf

Material

- 0.95mm high tensile cold rolled mild steel shelves
- 1.20mm cold rolled mild steel endplates

Finish

- Powder coated

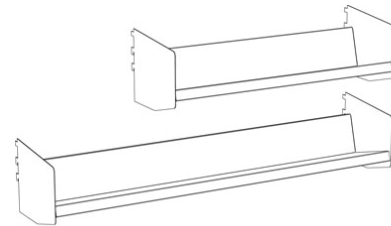

Code	Description	Weight (kg)
92523	CD/ DVD shelf 600mm wide x 150mm deep	2.17
92517	CD/ DVD shelf 900mm wide x 150mm deep	2.89

2.2.29 VIDEO SHELF

An angled shelf unit for the display (spine out) of video cassettes. The back slope helps to keep the product on the shelf

Material

- 0.95mm high tensile cold rolled mild steel shelves
- 1.20mm cold rolled mild steel endplates

Finish

- Powder coated

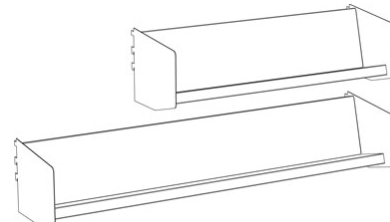

Code	Description	Weight (kg)
92524	Video shelf 600mm wide x 100mm deep	2.17
92521	Video shelf 900mm wide x 100mm deep	2.89

2.2.30 CD/ DVD DISPLAY SHELF

An angle display shelf with mid point horizontal ledge to provide 2 levels of CD or DVD display (cover face out). Part number includes Quadrant end plates.

Material

0.75mm high tensile cold rolled mild steel shelf
1.60mm cold rolled mild steel endplates

Finish

Powder coated

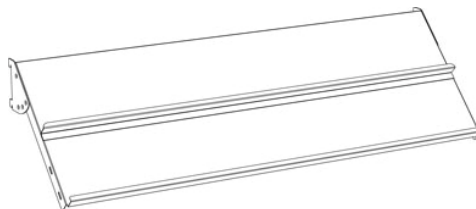

Code	Description	Weight (kg)
92574	CD/ DVD display shelf 900mm x 305mm	2.54

2.2.31 CD/ DVD DISPLAY RACKS

Compartmented trays for the display and storage of mass CD's or DVD's (cover face out). Combining 1, 2 or 4 tier units in a display creates a waterfall effect which optimises visibility and accessibility

Material

0.95mm high tensile cold rolled mild steel shelves
1.60mm cold rolled mild steel endplates

Finish

Powder coated

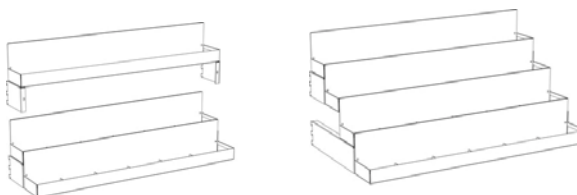

Code	Description	Weight (kg)
92575	CD/ DVD display rack 900mm – 1 tier	2.82
92576	CD/ DVD display rack 900mm – 2 tier	5.24
92577	CD/ DVD display rack 900mm – 4 tier	11.14

2.2.32 CD/ DVD DISPLAY FRAME

A freestanding 4 tier compartmented unit for the display and storage of mass CD's or DVD's (cover face out).

Material

2.00mm and 1.20mm tube frame
0.95mm high tensile cold rolled mild steel shelves
1.60mm cold rolled mild steel endplates

Finish

Powder coated

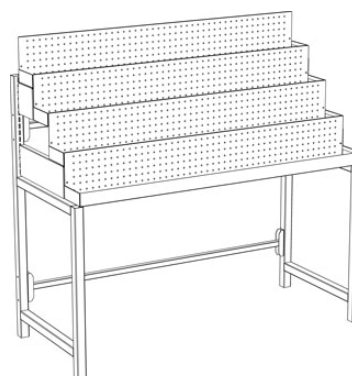

Code	Description	Weight (kg)
92777	CD/ DVD display frame 4 tier 1050mm high x 1260mm wide x 535mm deep	28.50

2.2.33 BROWSER BINS

A bin with adjustable dividers for the front facing display and storage of picture books. Used with 305mm overslung endplates 92546 (ordered separately).

Material

1.20mm cold rolled mild steel

Finish

Powder coated

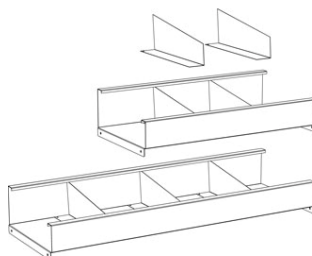

Code	Description	Weight (kg)
92579	Browser bin 600mm x 305mm x 120mm high (back) x 80mm high (front) – with 2 dividers	3.65
92520	Browser bin 900mm x 305mm x 120mm high (back) x 80mm high (front) – with 3 dividers	5.41
92580	Browser bin dividers (extra)	0.21

2.2.34 HANGING BAG RAIL

For storage of 'coat hanger' style hanging storage bags. Used with 203mm overslung endplates 92543 (ordered separately).

Material

9.50mm diameter steel tube rail
0.95mm cold rolled mild steel brackets

Finish

Powder coated



Code	Description	Weight (kg)
92514	Hanging bag rail 900mm	0.67

2.2.35 ZIG-ZAG SHELF DISPLAY

This unit sits onto any standard 900mm wide flat upstand shelf and provides an attractive display for books. Ideal for new releases.

Material

1.60mm cold rolled mild steel

Finish

Powder coated

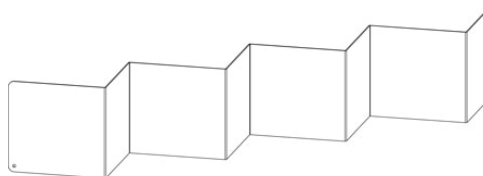

Code	Description	Weight (kg)
92518	Zig-Zag Display 900mm	2.43

2.2.36 BOOKSHELF INDICATOR

Bookshelf indicators sit over the front edge of a standard flat library shelf and used to separate library categories. Applied vinyl graphics can be added to the front spine to indicate specific categories and ranges (Alphabetic or dewy decimal). Graphics are not included as part of the standard product.

Material

0.95mm high tensile cold rolled mild steel

Finish

Powder coated

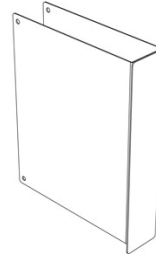

Code	Description	Weight (kg)
92581	Book shelf indicator 190mm high x 150mm deep x 40mm wide	0.59

2.2.37 FLOOR FIXING BRACKETS

Securely fix double faced freestanding shelving units using this bracket attached to the centre of each post then fixed into floor below (refer to assembly instructions for further details). Brackets sold in pairs.

Material

2.00mm cold rolled mild steel

Finish

Powder coated

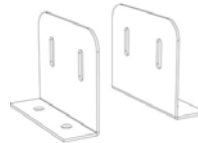

Code	Description	Weight (kg)
92582	Floor fixing bracket (pair)	0.34

2.2.38 OVERHEAD BRACES

Located into the top of library posts, and used in conjunction with overhead splices, the overhead braces tie runs of freestanding shelving together, providing protection from tipping over during seismic activity. Single faced braces are used on the end shelving units and the double faced braces are used on intermediate runs (refer to assembly instructions for further details).

Material

1.60mm and 2.00mm cold rolled mild steel

Finish

Powder coated

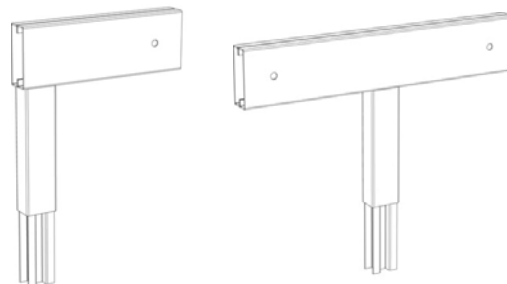

Code	Description	Weight (kg)
92583	Overhead 'L' brace (single faced)	2.36
92584	Overhead 'T' brace (double faced)	3.37

2.2.39 OVERHEAD SPLICES

These splices span between the overhead braces and bolted into place, tying runs of freestanding shelving together. Select the length of splice to best suit required aisle width. (refer to assembly instructions for further details).

Material

2.00mm cold rolled mild steel

Sizes

1450mm

To suit aisle width (posts centre to centre) range of 1150mm to 1650mm at 50mm increments

1800mm

To suit aisle width (posts centre to centre) range of 1500mm to 2000mm at 50mm increments

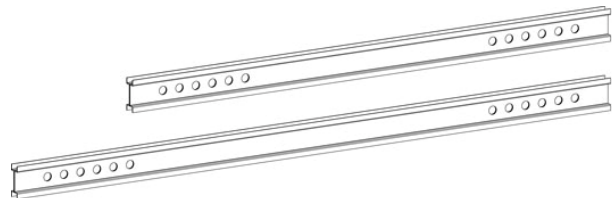

Finish

Powder coated

Code	Description	Weight (kg)
92585	Overhead splice 1450mm	5.02
92586	Overhead splice 1800mm	6.27

2.2.40 SEISMIC CROSS BRACES

These optional braces are supplied in pairs and span diagonally, vertically, between posts to provide further lateral rigidity within shelving units. Please refer to the '3.2.3 Secure Fixing' section within this manual for recommended positions of these cross braces. Each kit comprises of 2 x cross braces, 4 x mounting brackets, 2 x turn buckles and all fixings

Note: Seismic cross braces can not be used on end posts that have end panels attached.

Material

2.00mm cold rolled mild steel

Sizes

To suit standard post heights

Finish

Powder coated braces and brackets
Galvanised turn buckle



Code	Description	Weight (kg)
92780	Seismic cross brace kit for 1205mm posts	0.78
92782	Seismic cross brace kit for 1510mm posts	0.91
92784	Seismic cross brace kit for 1815mm posts	1.06
92785	Seismic cross brace kit for 1965mm posts	1.14
92786	Seismic cross brace kit for 2120mm posts	1.23
92787	Seismic cross brace kit for 2270mm posts	1.31

2.2.41 END PANELS - PLAIN

Attached to the end of shelving runs, plain end panels are used to define library sections, identify aisle contents, or simply to provide aesthetic relief.

Material

0.95mm high tensile cold rolled mild steel

Sizes

- 1200mm high x 670mm wide (305mm DF)
- 1505mm high x 670mm wide (305mm DF)
- 1810mm high x 670mm wide (305mm DF)
- 1960mm high x 670mm wide (305mm DF)
- 2115mm high x 670mm wide (305mm DF)
- 2265mm high x 670mm wide (305mm DF)

Finish

Powder coated

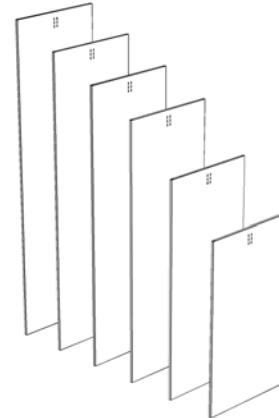

Code	Description	Weight (kg)
92728	End panel plain 1200mm x 670mm (305mm double faced)	7.64
92730	End panel plain 1505mm x 670mm (305mm double faced)	9.54
92732	End panel plain 1810mm x 670mm (305mm double faced)	11.44
92733	End panel plain 1960mm x 670mm (305mm double faced)	12.39
92734	End panel plain 2115mm x 670mm (305mm double faced)	13.35
92735	End panel plain 2265mm x 670mm (305mm double faced)	14.30

2.2.42 END PANELS - DISPLAY

Attached to the end of shelving runs, display end panels are used to define library sections, identify aisle contents, display material, or simply to provide aesthetic relief. The vertical slots are designed to hold standard 600mm wide shelving and accessories, whilst the circular punchings accommodate angled display shelves.

Material

0.95mm high tensile cold rolled mild steel

Sizes

- 1200mm high x 670mm wide (305mm DF)
- 1505mm high x 670mm wide (305mm DF)
- 1810mm high x 670mm wide (305mm DF)
- 1960mm high x 670mm wide (305mm DF)
- 2115mm high x 670mm wide (305mm DF)
- 2265mm high x 670mm wide (305mm DF)

Finish

Powder coated

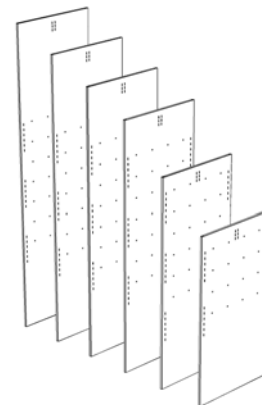

Code	Description	Weight (kg)
92738	End panel display 1200mm x 670mm (305mm double faced)	7.60
92740	End panel display 1505mm x 670mm (305mm double faced)	9.47
92742	End panel display 1810mm x 670mm (305mm double faced)	11.38
92743	End panel display 1960mm x 670mm (305mm double faced)	12.33
92744	End panel display 2115mm x 670mm (305mm double faced)	13.29
92745	End panel display 2265mm x 670mm (305mm double faced)	14.23

2.2.43 END PANEL DISPLAY SHELF

An angled display shelf that clips into the circular holes of a display end panel.

Material

0.95mm high tensile cold rolled mild steel

Finish

Powder coated

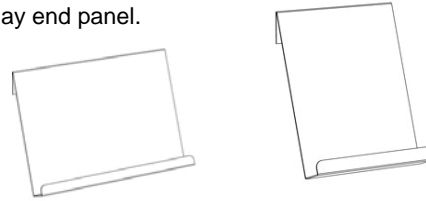

Code	Description	Weight (kg)
92598	End panel display shelf 190mm wide	0.62
92597	End panel display shelf 340mm wide	1.10

2.2.44 END PANEL FIXING KIT

These kits comprise of 2 types of brackets to fix timber or laminated panels to the end of shelving runs. The top brackets slot into the posts utilising the spare outer centre brace slots; the bottom brackets hook over the post base RHS. The panels are then screw fixed from the inside using the 2 holes in each bracket.

Material

1.20mm cold rolled mild steel

Finish

Powder coated

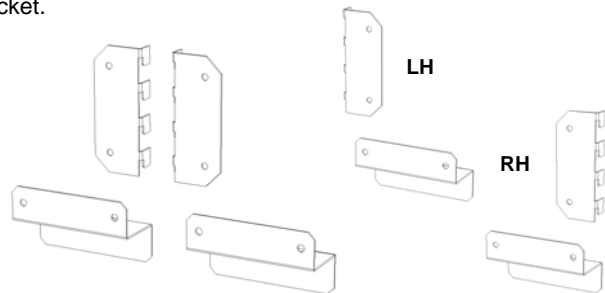

Code	Description	Weight (kg)
92746	End panel fixing kit for double faced panels	0.26
92775	End panel fixing kit for single faced panels – left hand	0.13
92776	End panel fixing kit for single faced panels – right hand	0.13

2.2.45 RANGE LABEL HOLDER

A two way label holder that can be fixed to the ends of the shelving runs to identify the contents held within the run. The holders slot into the spare outer centre brace slots and can also be used when end panels are installed to the runs.

Card size is 125mm wide x 65mm high

Material

0.75mm high tensile cold rolled mild steel

Finish

Powder coated

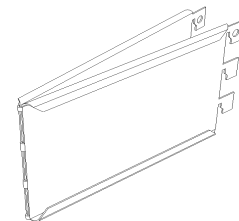

Code	Description	Weight (kg)
92771	Range label holder	0.62

SECTION 3 – DESIGNERS REFERENCE

3.1 DEFINITIONS

To eliminate possible confusion when describing or specifying library shelving installations, the following definitions should be used. These apply to all types of shelving installations.

A shelving **Bay** describes the unit of modularity in the left-to-right (L-R) plane.

A **Unit** describes the collective number of bays joined together, or overall length of shelving required.
e.g. 'The 3 units of library shelving are all to be 3 x 900mm bays long'

All dimensions should be as given below:

Dimensions in the L-R plane of the unit are expressed as **Length** or **Width**

*e.g. W = Bay width
L = Unit length*

Dimensions in the front-to-back (F-B) plane of the unit are expressed as **Depth**. Dimensions in the vertical plane are expressed as **Height** and are relative to the floor level.

*e.g. D = Unit depth
H = Unit height*

Aisles are the clear distance between shelving units and is the space available for passage

Vertical Clear Entry is the distance between the top surface of one shelf and the underside of the next shelf above. This dimension will be the centre-to-centre spacing of the shelves less the 25.4mm vertical height of the shelf flange.

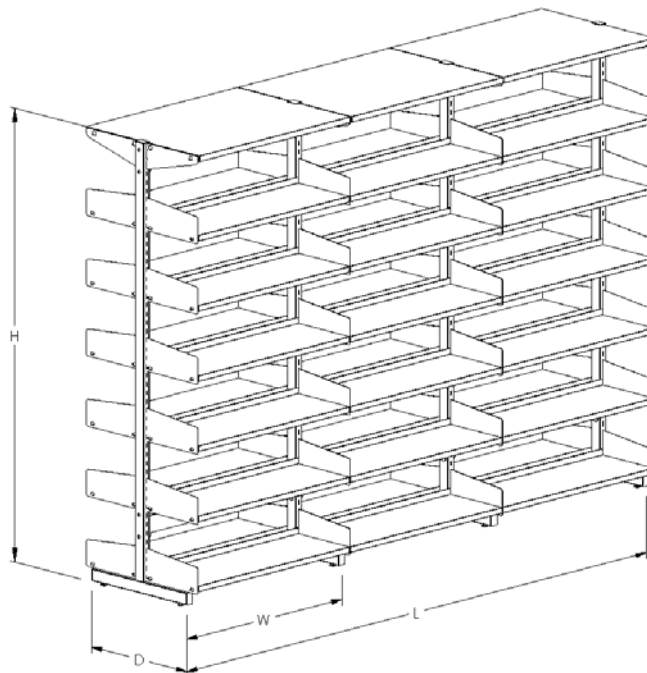

The following definitions describe the most frequently types of unit:

Wall mounted units comprise of slotted channel fixed to wall, at required centres, with shelving and accessories hanging off one side only

Single faced units comprise of freestanding post and tie strut frames with shelving and accessories hanging off one sides only. Our recommendation is that all single faced units are restrained back to walls.

Double faced units comprise of freestanding post and tie strut frames with shelving and accessories hanging off both sides.

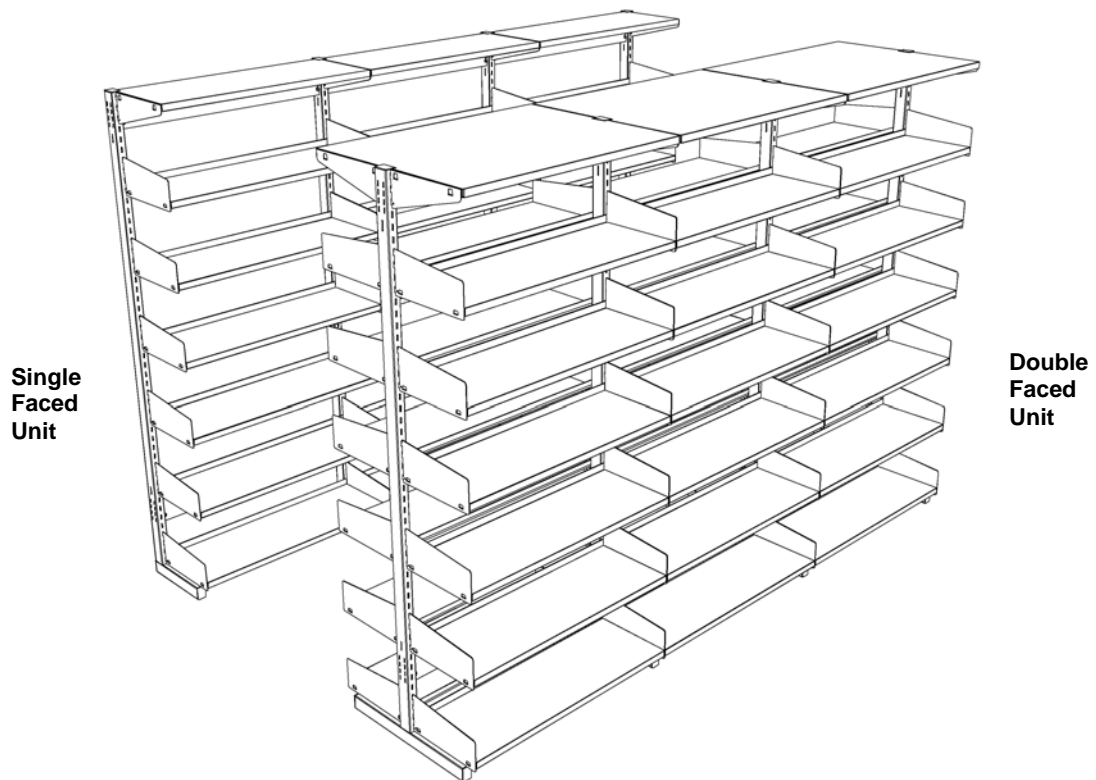

3.2 GENERAL LAYOUT

3.2.1 WALL MOUNTED SHELVING

3.2.1.1 Wall channel dimensions

- 2438mm high x 35mm wide x 13mm deep
- 20mm high x 4.5mm wide slots @ 38.1mm centres
- 5.5mm diameter countersunk fixing holes at 76.2mm centres

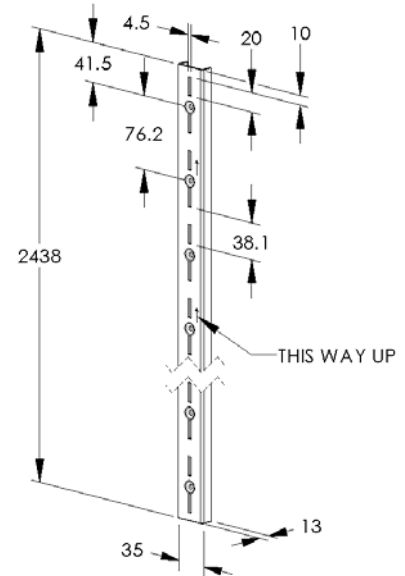

3.2.1.2 Bay dimensions

- Centre to centre (Y)
- 903mm or 603mm

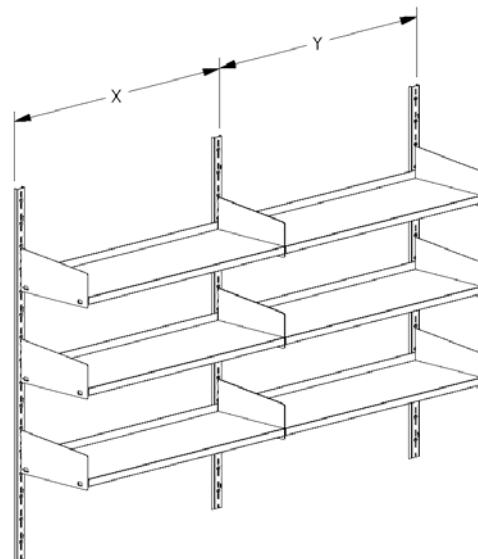
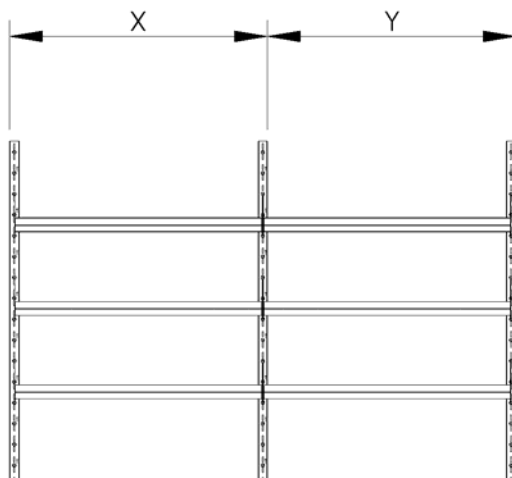

3.2.1.3 Overall dimensions

- 900mm module
 - First bay (X) – 938mm
 - Every additional bay (Y) – 903mm
- 600mm module
 - First bay (X) – 638mm
 - Every additional bay (Y) – 603mm

3.2.2 FREESTANDING LIBRARY SHELVING

3.2.2.1 Post dimensions

Heights, as published, are overall height of post and include base, leveling foot (fully inserted) and plastic top cap

Base dimension

- Single faced – 312mm
- Double faced – 565mm
- Post section is 51mm x 35mm
- 19mm high x 4.8mm wide slots @ 38.1mm centres

3.2.2.2 Bay dimensions

- Centre to centre (Y)
903mm or 603mm

3.2.2.3 Overall dimensions

- 900mm module
First bay (X) – 938mm
Every additional bay (Y) – 903mm
- 600mm module
First bay (X) – 638mm
Every additional bay (Y) – 603mm

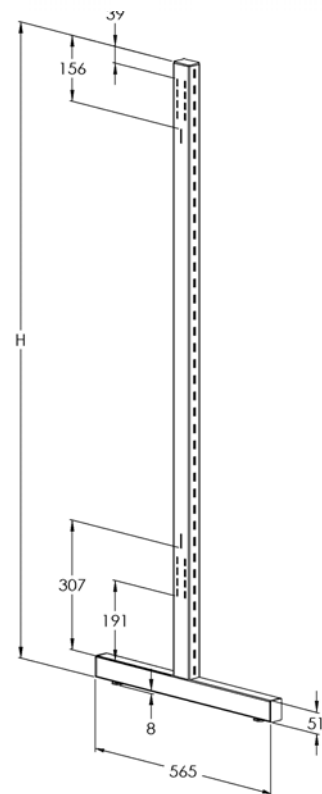
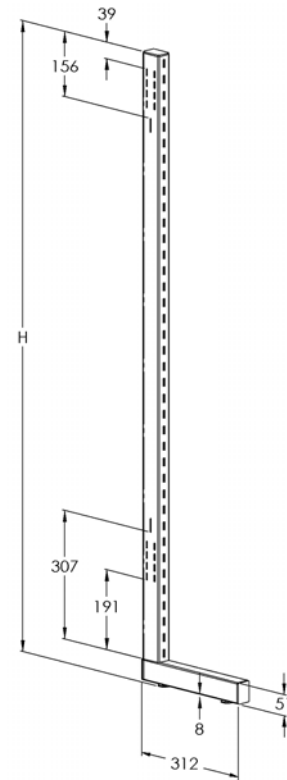
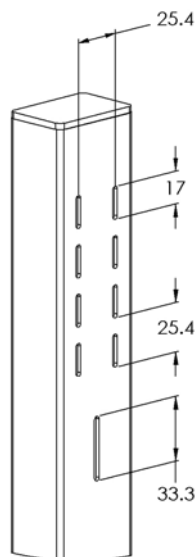

3.2.3 SECURE FIXING

3.2.3.1 New Zealand standards

NZS4104:1994, Seismic Restraint of Building Contents recommends that any fixture over the height of 1200mm be suitably restrained to protect against tipping over.

3.2.3.2 Wall mounted shelving

Must be securely fixed in accordance with the Precision Library shelving Installation manual.

3.2.3.3 Single sided freestanding shelving

Precision recommends that all single sided freestanding shelving be fixed back to the wall. A centrally located wall fixing bracket is located over the top tie strut and fixed to wall in accordance with the Precision Library shelving Installation manual.

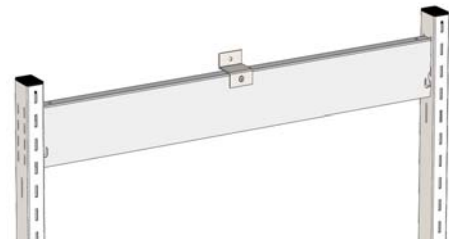

3.2.3.4 Double sided freestanding shelving

Precision recommends that all double sided freestanding shelving be secured using one (or both) of two methods:

1. In accordance with the Precision Library shelving Installation manual, floor fixing brackets can be attached to the base of each upright then fixed to the floor



2. Overhead bracing is designed to connect runs of library shelving together to become one stable structure in the unlikely event of seismic activity. Overhead bracing should span between shelving runs every two bays.

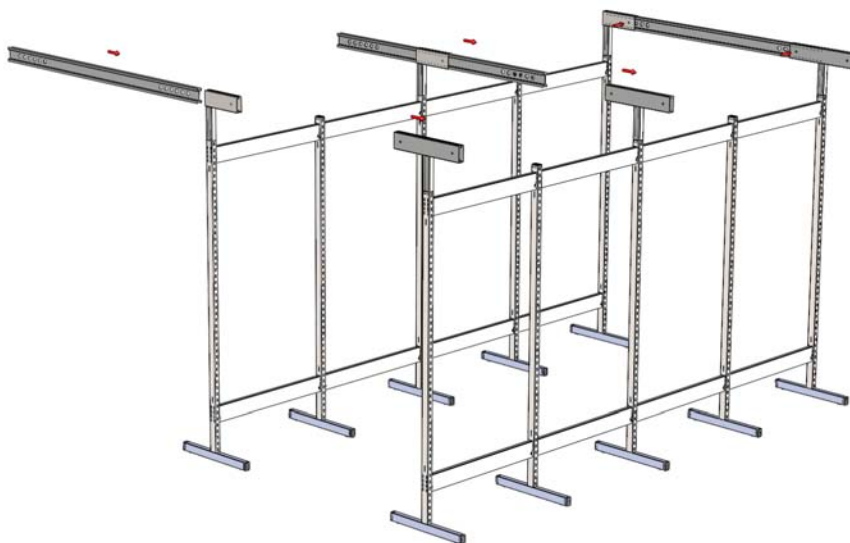

3. For additional lateral rigidity, especially during seismic activity, Precision recommends the inclusion of seismic cross braces between shelving bays. One pair should be installed to every 3rd bay of the library shelving run, as per example shown below.



Plan

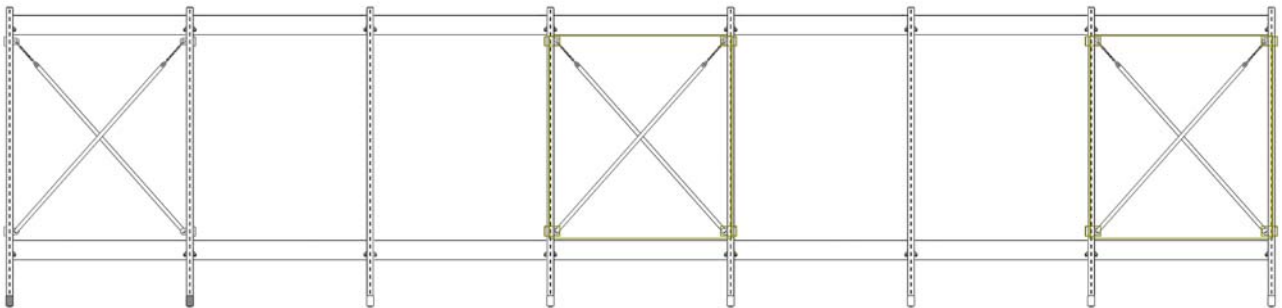

Elevation

Note: seismic cross braces can not be used on end posts that have end panels attached.

3.2.4 FLOOR QUALITY

A careful study of the floor and its loading capability should be carried out by the customer to ensure suitability for the proposed installation

3.2.5 STORAGE CAPACITY

The following charts give the maximum amount of storage height available for any given combination of shelves on any post height. For example, if you require a post with maximum height of 1510mm and four shelves, the maximum amount of storage height available will be 1365mm. These charts have been calculated using a canopy shelf in position. Storage height would increase if canopy is not used.

Number of Shelves		2	3	4	5	6	7	8	9
Legless Post height									
1205mm	Total amount of filing height available (mm)	1055	1030	1005	-	-	-	-	-
1510mm		-	1335	1310	1285	1260	-	-	-
1815mm		-	-	1615	1590	1565	1540	-	-
1965mm		-	-	1765	1740	1715	1690	1665	-
2120mm		-	-	-	1895	1870	1845	1820	-
2270mm		-	-	-	2045	2020	1995	1970	1945

3.3 LOAD INFORMATION

3.3.1 GENERAL

The following load information shows the maximum allowable shelf loads and maximum allowable bay loads. All load information has been tested in accordance with AS2273-1979, Australian Standard for Steel Library Shelving

3.3.2 SHELF LOADS

The range of shelves, inclusive of both 600mm and 900mm width and their respective available depths, have been tested and rated in accordance with AS2273-1979 at a load bearing capacity of 50kg. **Where the load bearing capacity is required to exceed the rated 50kg, please refer your requirements to our technical department.**

3.3.3 BAY LOADS

The bay load ratings are dependant on size, layout and method of restraint.

Legless Post Height (mm)	Bay Style				
	Single Faced Maximum Loading (kg)		Double Faced Maximum Loading (kg)		
	Restrained	Unrestrained	Restrained	Unrestrained	'Out of Balance'
1205	400	400	600	600	400
1510	400	290	600	600	290
1815	400	200	600	600	200
1965	400	160	600	600	160
2120	400	150	600	600	150
2270	400	120	600	600	120

Note! 'Out of balance' bay load refers to the maximum variation in load per face of the bay e.g. for a fully loaded 2270 Double Faced bay, the loading per face should in the worst case be 360 and 240 respectively.

3.4 STANDARD BAY CONSTRUCTION TIMES

Description	Unit of Measure	Estimated Labour
Freestanding single faced bay	Per bay	20 min
Freestanding double faced bay	Per bay	30 min
Wall mounted	Per bay	30 min
Battens for wall mounted (if required)	Per bay	15 min
Shelves and endplates	Per set	1 min
Sloping shelves	Per set	3 min
End panels	Each	10 min
Accessories - small	Each	10 min
Accessories – large	Each	15 min
Overhead bracing	Each	10 min
Wall fixing brackets	Each	5 min
Floor fixing brackets	Each	10 min
Loading in	Single bay	5 min
Rubbish removal	Single bay	5 min